

Janet T. Mills  
Governor

Jeanne M. Lambrew, Ph.D.  
Commissioner



Maine Department of Health and Human Services  
Maine Center for Disease Control and Prevention  
11 State House Station  
286 Water Street  
Augusta, Maine 04333-0011  
Tel; (207) 287-8016; Fax (207) 287-9058  
TTY: Dial 711 (Maine Relay)

May 15, 2024

Ms. Mariya Moskovets  
Infiltrator Water Technologies  
4 Business Park Road  
P. O. Box 768  
Old Saybrook, CT 06475

Subject: Product Registration, Infiltrator IM-1250 tank

Dear Ms. Moskovets:

The Division of Environmental Health has completed a review of a registration application for the subject products. This information was submitted pursuant to Section 7 of the Subsurface Wastewater Disposal Rules for registration for use in Maine.

The IM-1250 consists of two-piece high-density polyethylene/polypropylene tank halves. The seam between the upper and lower halves is sealed with an elastomeric gasket. The IM-1250 tank has a 1,271-gallon capacity when used as a single- or dual-compartment septic tank. Risers are available for the IM-1250 tank.

Pursuant to Section 7 of the Rules, a product must be based upon sound engineering principles and can be expected to provide the same level of protection to public health and the environment as offered by the authorized products presently authorized by the Department for use in these Rules. According to the information you provided, the IM-1250 received a IAPMO R&T listing current as of May 2024.

Based on the information submitted, the Division has determined that Infiltrator's IM-1250 tank is acceptable for use in the State of Maine, provided that it is installed, operated, and maintained in conformance with the manufacturer's directions. Because installation and owner maintenance have a significant effect on the working order of onsite sewage disposal systems, including their components, the Division makes no representation or guarantee as to the efficiency and/or operation of the IM-1250 tank. Further, registration of this product for use in the State of Maine does not represent Division preference or recommendation for this product over similar or competing products.

If you have any questions, please feel free to contact me at (207) 287-5695.

Sincerely,

A handwritten signature in cursive script that reads 'Alexander L. Pugh'.

Alexander L. Pugh  
Sr. Environmental Hydrogeologist  
Division of Environmental Health  
Subsurface Wastewater Unit  
e-mail: alex.l.pugh@maine.gov



November 16, 2023

Alexander L. Pugh  
Sr. Environmental Hydrogeologist  
Division of Environmental Health  
Subsurface Wastewater Team  
Maine Department of Health and Human Services  
286 Water Street  
Augusta, Maine 04333-0011

Re: Request for Review and Registration of the Infiltrator IM-300 and IM-1250 Tanks

Dear Mr. Pugh,

Infiltrator Water Technologies (Infiltrator) has added two new tank models to its tank product line referred to as the IM-300 and IM-1250. The Maine Department of Health and Human Services, Division of Environmental and Community Health (Division) has previously reviewed product information on Infiltrator tanks and approved their use. We respectfully request the Division's review of the following information on the IM-300 and IM-1250 tanks and approval for their use in accordance with Section 7 of 10-144 CMR 241, the State of Maine Subsurface Wastewater Disposal Rules (Rules). Information supporting this request is provided below and in the attachments to this letter.

Infiltrator proposes to utilize the IM-300 and IM-1250 tanks in the following applications:

**Table 1** – Infiltrator IM-300 and IM-1250 tanks use summary

Tank Model	Recommended Application	
Infiltrator IM-300	278-gallon Working capacity septic tank in series with another tank	322-gallon total capacity pump/siphon tank
Infiltrator IM-1250	1,271-gallon effective capacity 1- or 2-compartment septic tank	1,479-gallon total capacity single-compartment pump tank

**Plan Submission Documentation**

Detailed design drawings for the Infiltrator IM-300 and IM-1250 tanks are provided as Attachment 1.

**Specifications as Compared to other Approved Infiltrator Tanks**

The Infiltrator IM-300 and IM-1250 tanks are designed using identical engineering principles as were applied in the development of the approved Infiltrator tank models.

The IM-300 design is similar to the IM-540 design in many respects, including corrugated tank body, wall thickness, mid-seam gasketed joint, and molding technology. Due to the IM-300 being 4 inches shorter in height than the IM-540, when used as a septic tank in series with another tank, the outlet invert of the IM-300 is located at 41.25 inches, as compared to 44 inches for the IM-540. The

alignment dowels for the IM-300 tank body are molded into the tanks body (also a feature of the approved CM-1060), as compared to this component being a separate part for the IM-540. A side-by-side comparison of the IM-300 and IM-540 is provided in Figure 1.



**Figure 1** – Proposed IM-300 (left) and approved IM-540 (right)

The IM-1250 design is most similar to the CM-1060 design, with the addition of two mid-body corrugations. The addition of two corrugations increases the volume, boosting the working capacity above 1,250 gallons through increased length. Similarities between the models include the corrugated tank body, wall thickness, and mid-seam gasketed joint. The alignment dowels for both models are molded into the tank body. Different forming technologies are used to create the tank body, with the IM-1250 employing injection molding, the same technology used for the IM-540, IM-1060, and IM-1530. The IM-1250 tank includes four vertical supports, as compared to two for the CM-1060. A side-by-side comparison of the IM-1250 and CM-1060 is provided in Figure 2.

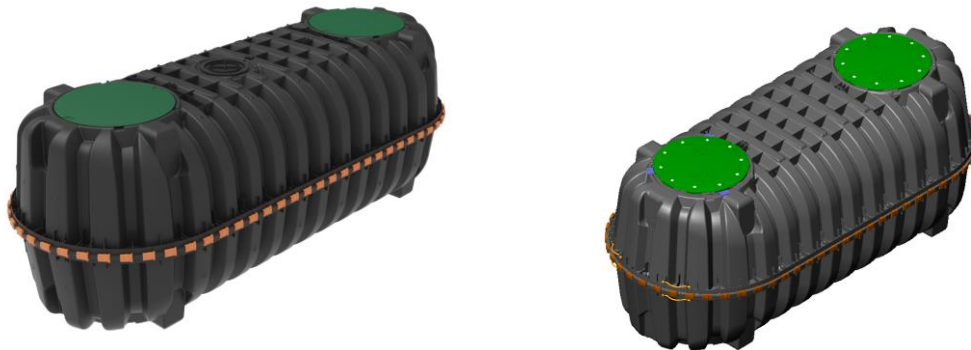

**Figure 2** – Proposed IM-1250 (left) and approved CM-1060 (right)

Table 2 provides a summary of common parameters between the approved IM-540 and CM-1060 models, and proposed IM-300 and IM-1250 tanks, respectively.

**Table 2 – Model comparisons**

Parameter	Approved IM-540	Proposed IM-300	Approved CM-1060	Proposed IM-1250
Liquid Level	44 inches	41.25 inches	44 inches	44 inches
Wall thickness	0.20 inches	0.20 inches	0.20 inches	0.20 inches
Vertical supports	0	0	2	4
Mid-seam joint	Elastomeric material	Elastomeric material	Elastomeric material	Elastomeric material
Alignment dowels	22	Molded-in	Molded-in	Molded-in
Locking clips	44	36	64	72
Lids	1	1	2	2
Inlet/outlet gaskets	1	1	2	2
Risers	1	1	2	2

### Compliance with Dimensional and Feature Requirements

Table 3 below provides a comparison of relevant requirements and proposed tank models attributes.

**Table 3 – Infiltrator IM-300 and IM-1250 dimensional compliance evaluation**

Parameter	Units	10-144 CMR 241 Requirements	Infiltrator IM-1250	Infiltrator IM-300
Liquid depth	inches	≥30	44	41.25
Distance between top of the outlet tee and top of the tank	inches	≥1	3.6	4.5
Inside length	inches	≥74	151.9	In series
Minimum width at liquid level	inches	≥36	52	In series
Inlet invert above outlet invert	inches	≥1	3	2
Access port diameter	inches	≥18	24	24
Liquid capacity	gallons	750	1,271	In series
First compartment sizing	%	66	65	In series

According to the Section 7(G)(6)(b) of the Rules, septic tanks shall have two compartments with at least 66% of the required capacity in the first compartment. Due to the structural design and repeat pattern of the IM-1250 tank body corrugations, the baffle cannot be positioned exactly at the 66% location, but it is positioned as close as possible at 65%. For a 5-bedroom home, the required septic tank effective capacity is 1,250 gallons, or 825 gallons in the first compartment. At 1,271 gallons of effective capacity, the IM-1250 tank provides 826 gallons in the first compartment, exceeding and meeting the intent of the 66% minimum requirement of the Rules.

### Structural Design and Watertightness

Both the IM-300 and IM-1250 are designed to withstand a 150 pound-per-cubic-foot soil dead load at a maximum burial depth of 52 and 48 inches, respectively. This load on the top of the tank can be applied when the tank is full or empty. Similar to the approved tank models, traffic loading is prohibited, but products are designed to support a 2,500-pound wheel load at a cover depth of 6 inches, corresponding to the load exerted by a typical pickup truck.

Like many precast concrete tanks, the IM-300 and IM-1250 are an assembly with corresponding top and bottom halves joined at a mid-level seam. Watertightness along the seam is provided by a continuous ASTM F477-certified elastomeric gasket seated in a molded groove in each tank model half and closed by a system of locking mechanical clips. In addition, all pipe inlet and outlet

penetrations employ watertight, non-corrosive and flexible gaskets designed for pipe-penetration purposes.

### **Installation Manual and Riser Connection Guidance Documents**

Installation instructions and a riser connection guidance document are provided in Attachment 2 and Attachment 3, respectively. These instructions detail the proper installation of the included tee and rubber gasket, the secure fastening of access opening lids, and include provisions for general installation conditions, suitable soils, and evaluating groundwater table conditions for buoyancy control needs. A QR code is provided on a label affixed to the outer surface of each tank, providing the user with electronic access to these documents on Infiltrator's web site.

### **CSA Certification**

Section 7(C)(4) of the Rules requires that polyethylene septic tanks must meet the requirements of the Canadian Standards Association (CSA) Standard B66-10 or the most current edition of the CSA tank standard. Infiltrator has initiated the CSA certification application for the IM-300 and IM-1250, and a late fall 2023 certification is anticipated for the IM-300, with the certification of the IM-1250 to follow several weeks later. Once the tanks achieve CSA certification, Infiltrator will provide a copy of the certificate under separate submissions. A placeholder for the expected CSA certification document is provided in Attachment 4.

### **Review and Approval Request**

The information provided in this letter demonstrates that Infiltrator's new IM-300 and IM-1250 tanks meet Maine's technical requirements for use in onsite wastewater systems. Infiltrator respectfully requests the Division to respond with a document similar to approvals issued for other Infiltrator tanks. A draft document modeled after the previous document issued for Infiltrator tanks is provided as Attachment 5.

Thank you in advance for your time and attention to this request. If any additional information is needed for your review of the IM-300 or IM-1250 tanks, please contact me at (860) 575-8617 or via email at [mmoskovets@infiltratorwater.com](mailto:mmoskovets@infiltratorwater.com).

Sincerely,



Mariya Moskovets  
Regulatory Project Engineer

cc: Dennis Healey, Infiltrator Water Technologies  
Todd Winkler, Infiltrator Water Technologies  
David Lentz, P. E., Infiltrator Water Technologies

Attachment 1

Design Drawings

G:\Technical Resources New\02-ISI\_PRODUCTS\14 - TANKS\01 -- IM-Series Tanks\IM-300

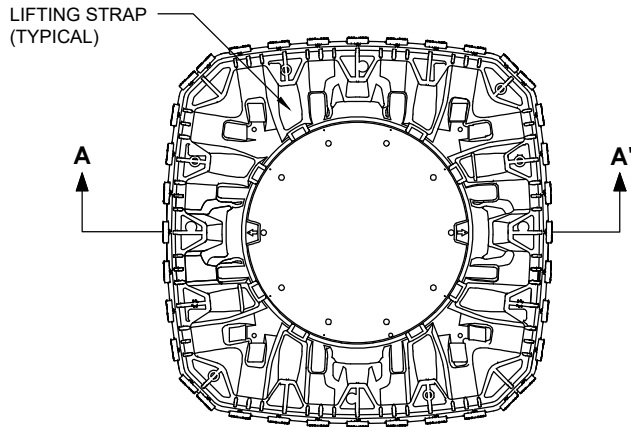

TOP VIEW

TANK EXTERIOR	
LENGTH	50.9 [1,293]
WIDTH	50.9 [1,293]
HEIGHT	50.5 [1,283]

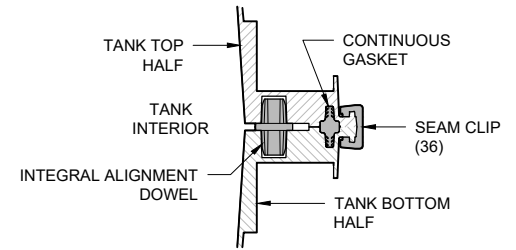

Ⓢ MID-HEIGHT SEAM SECTION DETAIL

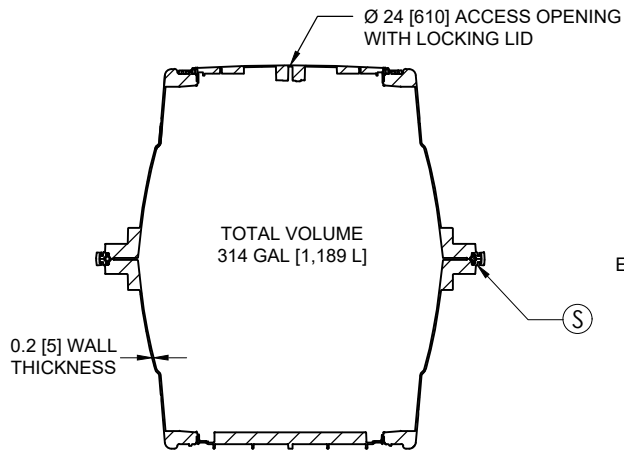

SECTION A - A'

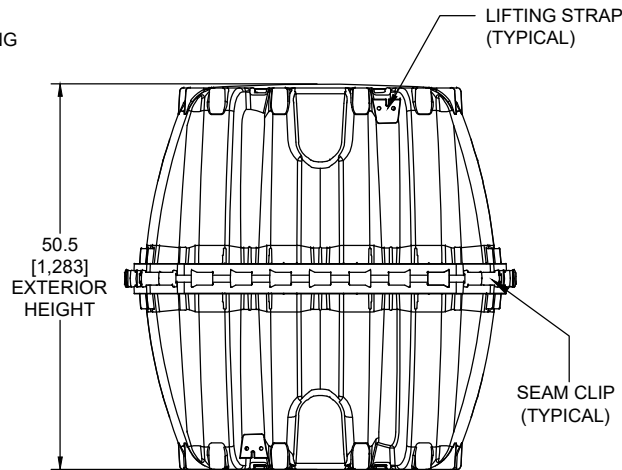

END VIEW

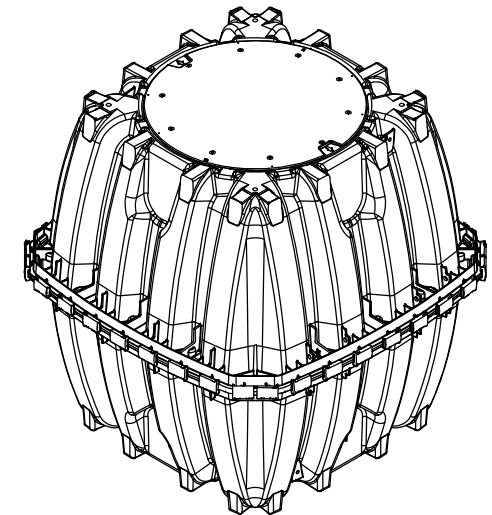

ISOMETRIC VIEW

**NOTES:**

1. ALL DRAWING DIMENSIONS IN INCHES [MILLIMETERS] OR AS NOTED.
2. EXTERIOR OF ACCESS OPENING LID INCLUDES THE FOLLOWING WARNING IN ENGLISH, FRENCH & SPANISH: "DANGER DO NOT ENTER: POISON GASES."
3. TANK MARKINGS INCLUDE: MANUFACTURER NAME, MODEL NUMBER, LIQUID CAPACITY, DATE OF MANUFACTURE CODE, MAXIMUM BURIAL DEPTH, INLET, AND OUTLET.
4. MAXIMUM BURIAL DEPTH IS 52 in [1,321 mm].
5. MINIMUM BURIAL DEPTH IS 6 in [152 mm].
6. TANK IS FOR NON-TRAFFIC APPLICATIONS.
7. NOMINAL WALL THICKNESS IS 0.2 in [5 mm].



INFILTRATOR WATER TECHNOLOGIES  
4 Business Park Rd. Old Saybrook, CT 06475  
(800) 221-4436

IM-300  
Pump Tank Configuration

Drawn by: KAJ	Edited by: JLK	Date: 05/11/2023
Scale: Not to scale	Checked by: DJL	Sheet: 1 of 1

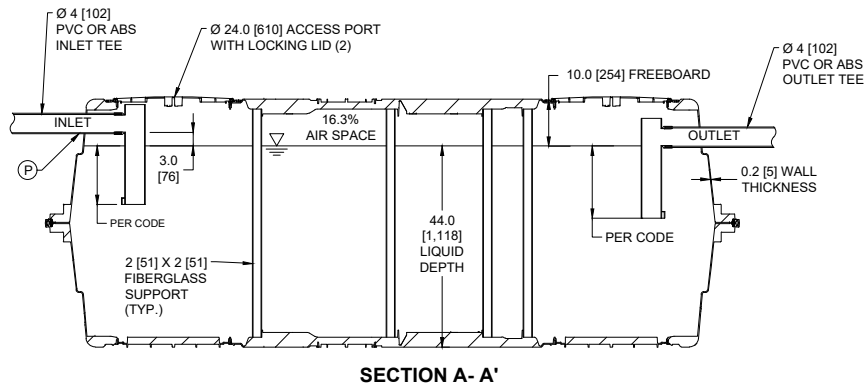
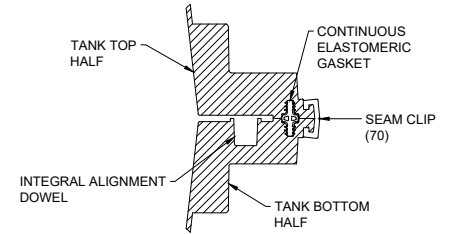
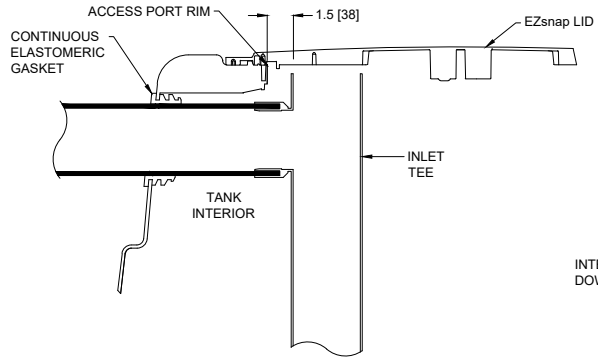
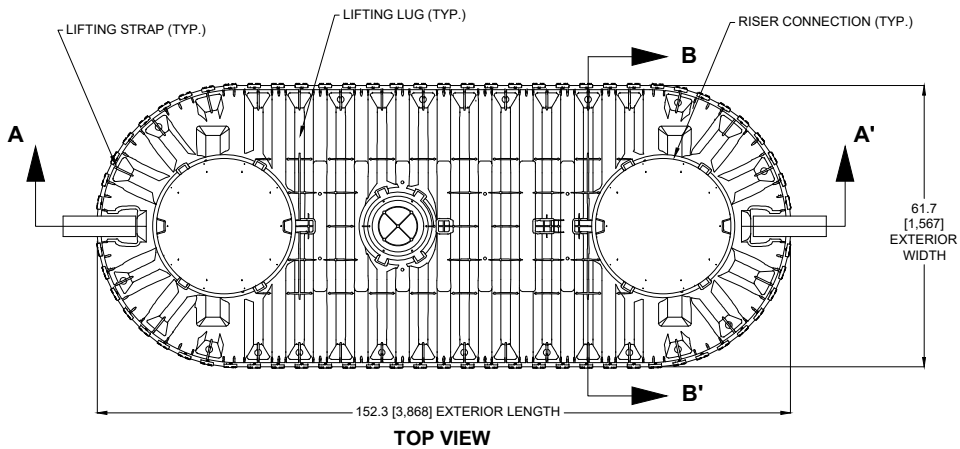

TANK EXTERIOR	
LENGTH	152.3 [3,868]
WIDTH	61.7 [1,567]
HEIGHT	54.6 [1,387]

LIQUID DEPTH	44.0 [1,118]
INVERT DROP	3.0 [76]
FREEBOARD	10.0 [254]

TOTAL CAPACITY	1,479 GAL [5,599 L]
WORKING VOLUME	1,271 GAL [4,811 L]

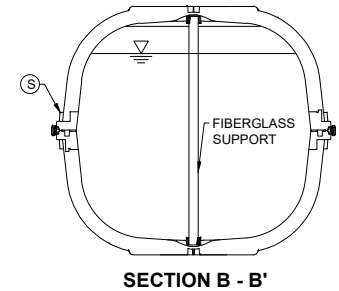
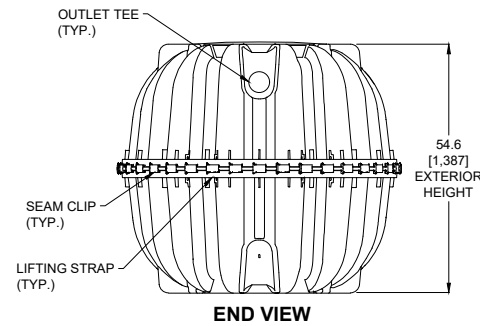

**NOTES:**

- ALL DRAWING DIMENSIONS IN INCHES [MILLIMETERS] OR AS NOTED.
- EXTERIOR OF ACCESS OPENING LID INCLUDES THE FOLLOWING WARNING IN ENGLISH, FRENCH & SPANISH: "DANGER DO NOT ENTER: POISON GASES."
- TANK MARKINGS WILL INCLUDE: MANUFACTURER NAME, MODEL NUMBER, LIQUID CAPACITY, DATE OF MANUFACTURE, MAXIMUM BURIAL DEPTH, INLET, AND OUTLET.
- MAXIMUM BURIAL DEPTH IS 48 in [1,219 mm].
- MINIMUM BURIAL DEPTH IS 6 in [152 mm].
- TANK IS FOR NON-TRAFFIC APPLICATIONS.
- AIRSPACE IS 16.3%.
- OUTLET TEE IS COMPATIBLE WITH AN EFFLUENT FILTER.
- LENGTH TO WIDTH RATIO IS 2.8:1 (143.9-INCH LENGTH / 51.8-INCH WIDTH = 2.8).

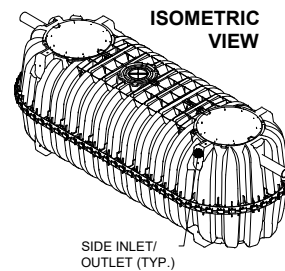

SIDE INLET/  
OUTLET (TYP.)



INFILTRATOR WATER TECHNOLOGIES  
4 Business Park Rd. Old Saybrook, CT 06475  
(800) 221-4436

IM-1250  
1-Compartment  
Septic Tank Configuration

Drawn by: KJ	Date: 4/6/2023
Scale: NOT TO SCALE	Sheet: 1 of 1

Checked by: JLK



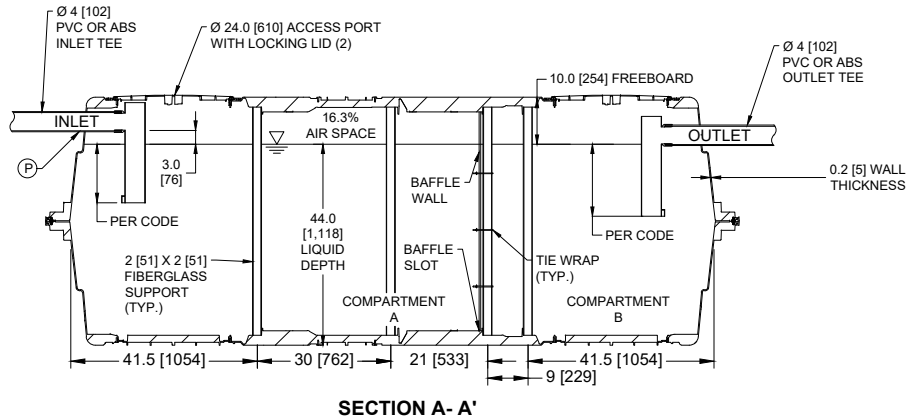
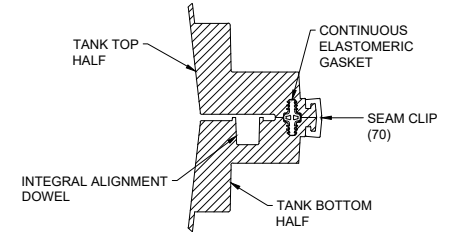
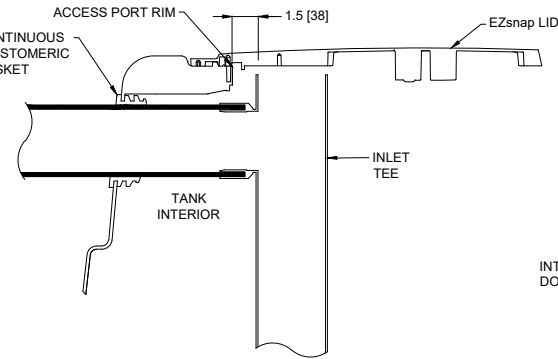
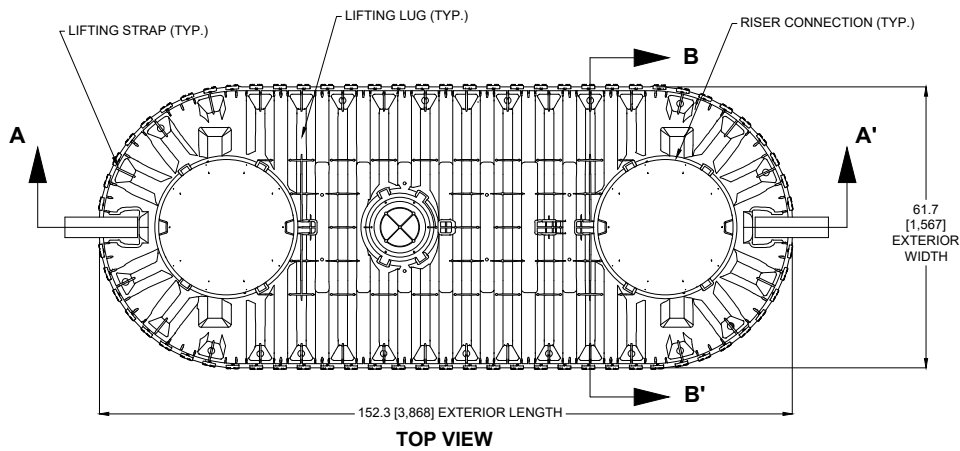

TANK EXTERIOR	
LENGTH	152.3 [3,868]
WIDTH	61.7 [1,567]
HEIGHT	54.6 [1,387]

LIQUID DEPTH	44.0 [1,118]
INVERT DROP	3.0 [76]
FREEBOARD	10.0 [254]

TOTAL CAPACITY	1,479 GAL [5,599 L]
WORKING VOLUME	1,271 GAL [4,811 L]
COMPARTMENT A VOL.	826 GAL [3,127 L]
COMPARTMENT B VOL.	445 GAL [1,684 L]

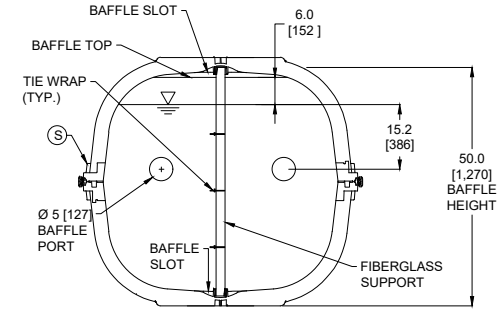
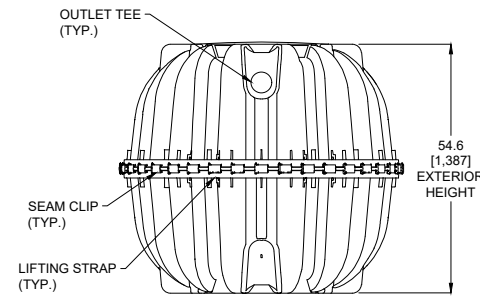

**NOTES:**

- ALL DRAWING DIMENSIONS IN INCHES [MILLIMETERS] OR AS NOTED.
- EXTERIOR OF ACCESS OPENING LID INCLUDES THE FOLLOWING WARNING IN ENGLISH, FRENCH & SPANISH: "DANGER DO NOT ENTER: POISON GASES."
- TANK MARKINGS WILL INCLUDE: MANUFACTURER NAME, MODEL NUMBER, LIQUID CAPACITY, DATE OF MANUFACTURE, MAXIMUM BURIAL DEPTH, INLET, AND OUTLET.
- MAXIMUM BURIAL DEPTH IS 48 in [1,219 mm].
- MINIMUM BURIAL DEPTH IS 6 in [152 mm].
- TANK IS FOR NON-TRAFFIC APPLICATIONS.
- AIRSPACE IS 16.3%.
- OUTLET TEE IS COMPATIBLE WITH AN EFFLUENT FILTER.
- LENGTH TO WIDTH RATIO IS 2.8:1 (143.9-INCH LENGTH / 51.8-INCH WIDTH = 2.6).
- FREE VENT AREA BETWEEN TOP OF BAFFLE WALL AND BOTTOM OF TOP BAFFLE SLOT IS 129.7 in<sup>2</sup>.
- BAFFLE WALL THICKNESS IS 0.31 in [8 mm].

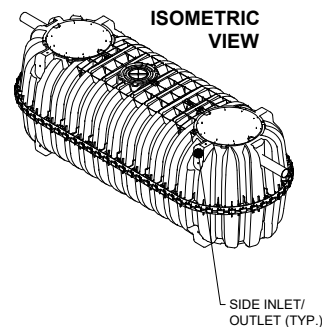

INFILTRATOR WATER TECHNOLOGIES  
4 Business Park Rd. Old Saybrook, CT 06475  
(800) 221-4436

IM-1250  
2-Compartment  
Septic Tank Configuration

Drawn by: KJ	Date: 4/6/2023
Scale: NOT TO SCALE	Checked by: JLK
	Sheet: 1 of 1

Attachment 2  
Installation Instructions

# Infiltrator Septic Tank

## General Installation Instructions

### BEFORE YOU BEGIN

Infiltrator Water Technologies' tanks must be installed according to state and/or local regulations and approvals, which supersede the manufacturer's installation instructions. If unsure of the installation requirements for a specific site, contact the health department or permitting authority. The Infiltrator Tank models referred to in this document include the IM-300, IM-540, IM-1060, CM-1060, IM-1250, and IM-1530.

**WARNING: IMPLOSIONS MAY CAUSE SERIOUS INJURY**  
Follow Infiltrator Water Technologies' vacuum test instructions

### MATERIALS AND EQUIPMENT NEEDED

<input type="checkbox"/> Infiltrator tank	<input type="checkbox"/> Shovel
<input type="checkbox"/> Access port lid(s)*	<input type="checkbox"/> Level
<input type="checkbox"/> 10 screws per lid*	<input type="checkbox"/> 5-inch-diameter (125 mm) hole saw
<input type="checkbox"/> Inlet/outlet gaskets (included)*	<input type="checkbox"/> Utility knife
<input type="checkbox"/> Inlet/outlet tees*	<input type="checkbox"/> PVC pipe glue with primer
<input type="checkbox"/> Tape measure	*Lid, gasket, and tee inclusion varies by state/province and tank model
<input type="checkbox"/> Pipe, risers, etc.	
<input type="checkbox"/> Socket wrench	
<input type="checkbox"/> Excavator	

### INSTALLATION SITE SELECTION

- Do not install the tank in vehicular traffic areas. The tank is designed for non-traffic applications.
- With the exception of the IM-300, the allowable soil cover depth is 6 to 48\* inches (150 to 1,200 mm). For the IM-300, the allowable soil cover depth is 6 to 52\* inches (150 to 1,321 mm). \*18-inch (450 mm) max. in Florida for Cat. 3 tanks; 48-inch (1,200 mm) max. in Florida for Cat. 4 tanks; and 36-inch (900 mm) max. in Massachusetts, New Hampshire, North Carolina, and Oregon.
- The tank shall not be installed where the subsurface water level outside the tank exceeds the height of the outlet pipe saddle. See page 6 illustration. See installation terminology on page 6 for Indiana installations.

### EXCAVATING AND PREPARING THE SITE

- Unless buoyancy control measures are required, the excavation width and length should be 18 to 36 inches (450 to 900 mm) larger than the tank on each side or sized as necessary to ensure proper backfill compaction, as outlined in Steps 5-10 of "Backfilling the Tank" in this document. See Infiltrator Tank Buoyancy Control Guidance document, available online at [www.infiltratorwater.com](http://www.infiltratorwater.com), for specific excavation requirements when installing with buoyancy control measures.
- With the exception of the IM-300, excavation depth shall account for the 55-inch (1,375 mm) tank height. The IM-300 height is 50.5 inches (1,283 mm). Account for 4 inches (100 mm) of bedding (if required) and cover depth.

**Note: If the water level outside the tank exceeds the height of the outlet pipe saddle, tank structural integrity may be compromised. See page 6 for maximum allowable subsurface water elevation guidelines. See page 6 note. Indiana Installations: If the depth of the uninterrupted saturated soil conditions cannot be determined from the site soil evaluation report or other site-related data and other information indicates the possible presence of a perched ground water table, tank installation is permissible. See installation terminology on page 6.**

- Inspect bottom of excavation to verify suitability of native soil for tank installation. Soils with large, protruding, or sharp stones or other similar objects that may damage the tank are not suitable.
- The tank may be installed either in suitable native soil (see Backfilling the Tank section) or a minimum 4-inch (100 mm) layer of well-graded granular soil having particles less than 3 inches (75 mm) in diameter, or maximum 0.5-inch (13 mm) diameter crushed stone.
- Create a uniform, compacted, level surface to ensure that the bottom of the tank is evenly supported. Verify that the installation surface is flat.

All Tank Models Except IM-300

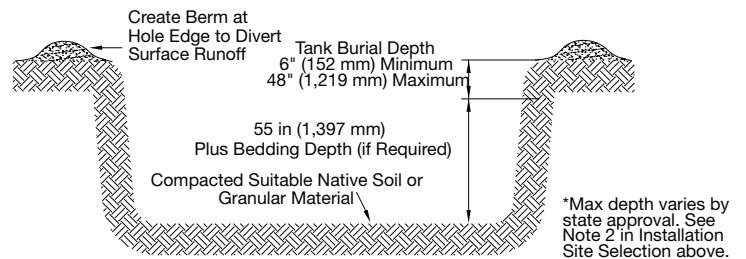

IM-300

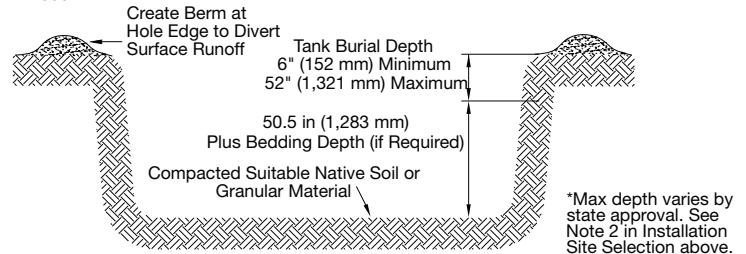

### INSTALLING THE TANK

- Inspect the tank for damage before installation.
- If the tank inlet and outlet penetrations are not drilled, drill holes using the drill points provided at each of the inlet and outlet ports according to Table 4 in the Inlet and Outlet Hole Locations section. The inlet and outlet may be drilled on either the sides or ends of the tank, as required based on applicable codes and site conditions.\*
  - \* Kentucky and West Virginia tanks are factory-drilled. Florida and Oregon tanks must be factory- or distributor-drilled.
- The gaskets supplied with the tank are compatible with Schedule 40 and SDR 35 pipe using a 5-inch-diameter (125 mm) hole saw.
- Install the rubber gaskets at the inlet and outlet.
- Using all four of the tank's integral lifting lugs, lower tank into excavation.
- Slide the inlet and outlet pipes\* through the gaskets. Soapy lubricant may be used to slide the pipe in.
  - \*For North Carolina, the inlet pipe shall be a straight pipe with no tee.
- Horizontally position the tee 1½ inches (38 mm) from the access port rim, allowing the tee to fit into the recess in the access port lid (see detail).

8. Install lids and risers (see Installing Risers section) as necessary. Rotate lid over access opening until it indexes to tank and drops into position.

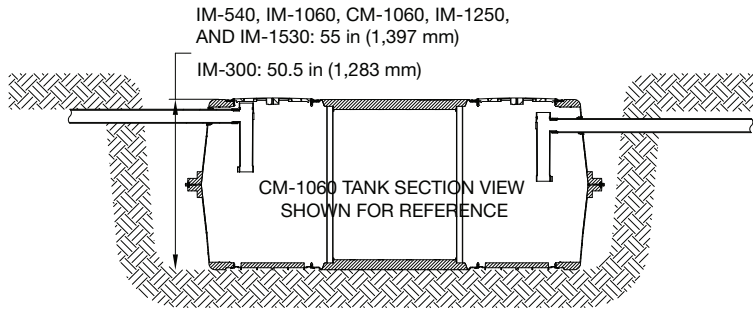
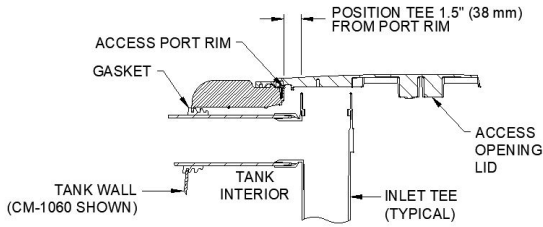

## BACKFILLING THE TANK

**Note: Infiltrator tanks do not require filling with water prior to backfill placement. Water filling and backfilling to the tank mid-height is required if the tank is left in either an open or backfilled excavation that may fill with water from rain or other sources.**

1. Backfill with suitable native soil (max. 3-inch (75-mm) stone diameter). If native soil is unsuitable, replace unsuitable fraction with suitable soil. If suitable soil is not locally available, contact Infiltrator for assistance.
2. Suitable soil shall include soil textural classes defined in the United States Department of Agriculture soil triangle.
  - a) For a tank soil cover depth of 0.5 to 2.0 feet (150 to 600 mm), suitable soil textures include:

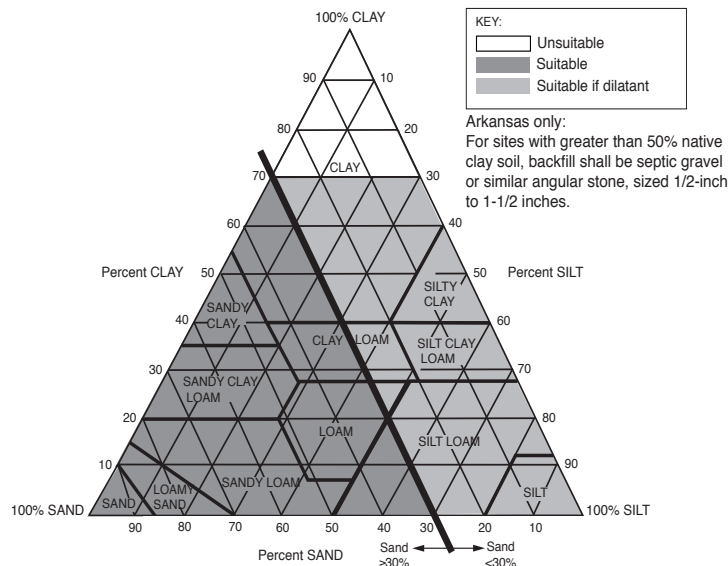

- b) For a tank soil cover depth that is greater than 2.0 feet and up to 4.0 feet (600 to 1,200 mm) for all tank models except IM-300, which is greater than 2.0 feet and up to 4.3 feet (600 to 1,300 mm), suitable soil textures include:

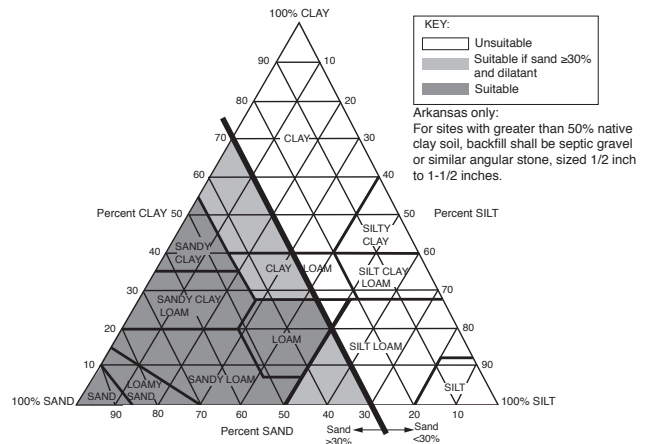

3. Backfill should not have stones greater than 3 inches (75 mm) in diameter or excessive clods that do not break apart during placement and compaction. Backfill must be capable of occupying the spaces between the tank ribs and beneath the haunches.
 

**Note: Rounded screened aggregate (e.g., pea gravel) is not a suitable backfill.**
4. Standard field soil classification methods shall be used to determine the soil textural class.
 

**Note: Under most circumstances, the determination of soil dilatancy will not be required. Dilatancy shall be determined in the field using a test that does not require specialized equipment, per ASTM D2488, Section 14.3.**
5. Place and compact soil by walking-in beneath the haunches of the tank.
 

**Note: Compacting soil beneath the haunches is critical for tank structural integrity.**
6. Place backfill around the four sidewalls in an alternating manner, so that the backfill height along the four sidewalls is maintained within a 12-inch (300-mm) tolerance.
7. Do not backfill top of tank before sidewalls are completely backfilled.
8. Continue to place backfill along the sidewalls in 12-inch (300-mm) lifts. Place backfill between the ribs on the sidewalls such that the space between the ribs is completely filled with soil.
9. Compact backfill material either by walking-in, hand tamping or mechanical compaction (includes backhoe bucket). If mechanical compaction is used, such as a walk-behind tamper or backhoe bucket, a single pass is recommended. Compact each lift prior to placement of next lift. Compact backfill from tank walls to excavation sidewalls.
10. Complete backfilling and grade the area.
11. A minimum 6-inch (150-mm) depth of suitable soil must be placed over the top of the tank. The balance of backfill placed to finish grade above the tank may be either suitable or unsuitable soil.
12. Establish a strong stand of erosion-resistant vegetation.
 

**Note: Grade to prevent the backfilled excavation from filling with surface runoff. If the subsurface water level in the backfilled excavation exceeds the height of the outlet pipe saddle, tank structural integrity may be compromised. See page 6 for illustration.**

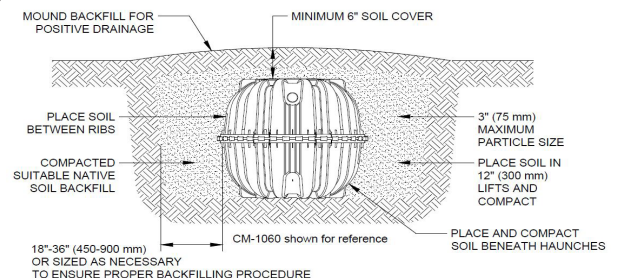

## SHORT AND LONG-TERM GROUNDWATER CONTROL

It may be necessary to implement groundwater control measures during tank installation. Maintain dry conditions by expanding the excavation to create a short-term groundwater collection sump for temporary placement of a dewatering pump if needed. Long-term groundwater control measures such as underdrains and interceptor trenches may be sensible if the site is amenable to construction of a control system and such systems are not prohibited by regulation or law, and the tank location is not subject to flooding. Underdrains and groundwater interceptor trenches may prevent the need for tank buoyancy control measures.

## INSTALLING UNDER SHALLOW GROUNDWATER CONDITIONS

Buoyancy control measures may be required if the tank is to be installed with less than 12 inches (300 mm) of soil backfill cover, and where the water level outside the tank (See Table 1, Note 5) has the potential to rise 30 inches (750 mm) or more above the elevation of the tank bottom. Otherwise, no control measures are required (see Table 1). The need for buoyancy control measures must be determined based on backfill cover depth and height of water outside of tank above the tank bottom according to Table 1. Refer to Infiltrator Tank Buoyancy Control Guidance document for more information.

**Table 1:** Infiltrator Tank Models<sup>1</sup> and Conditions Requiring Buoyancy Control

Parameter I: Subsurface water height above tank bottom		Parameter II: Soil cover depth above tank top <sup>2</sup>	
		A	B
		6 in (150 mm) up to 12 in (300 mm)	12 in (300 mm) or greater
1	Above outlet pipe saddle <sup>4</sup> (greater than 43" [1,075 mm])	Do not install tank	Do not install tank
2	36" (900 mm) to 43" (1,075 mm) <sup>4</sup> (to outlet pipe saddle)	All models except IM-300	Not Required
3	30" (750 mm) to 36" (900 mm)	IM-1530	Not Required
4	Less than 30" (750 mm)	Not Required	Not Required

### Notes:

- Infiltrator tank models include: IM-300, IM-540, IM-1060, CM-1060, IM-1250, and IM-1530.
- Minimum 6 inches (150 mm) soil cover backfill is required.
- Infiltrator tanks shall not be installed where the subsurface water level outside the tank exceeds the height of the outlet pipe saddle. See Figure 1.
- The height of the outlet pipe saddle for the IM-540, IM-1060, CM-1060, IM-1250, and IM-1530 is 43 in (1,075 mm). The height of the outlet pipe saddle for the IM-300 is 40.75 in (1,035 mm).
- For Indiana installations, if the depth of uninterrupted saturated soil conditions cannot be determined from the site soil evaluation report or other site-related data and other information indicates the possible presence of a perched ground water table, no buoyancy controls are required. See page 6 note on terminology.

## INSTALLING RISERS

- Compatible risers include 24-inch (600 mm) diameter products such as the Infiltrator EZsnap, TW-Riser, and EZset by Infiltrator, PolyLok<sup>®</sup>, Inc., and Tuf-Tite<sup>®</sup> Corporation, in addition to 24-inch (600 mm) diameter corrugated HDPE and IPEX Ultra Rib<sup>®</sup> PVC pipe. Follow Infiltrator's Tank Riser Connection Guidance Document.

- In Oregon only, watertightness testing shall include filling with water at least 2 inches above riser connection, with no more than 1 gallon leakage per 24 hours, per OAR 340-073-0025(3).

## INSTALLING PUMPS AND RELATED EQUIPMENT

Pumps may be supported on a stable, level 16x16-inch (400x400-mm) platform positioned on the bottom of the tank. One 16x16-inch block or two 8x16-inch (200 -mm x 400-mm) side-by-side blocks may be used. Limit block height to account for pump height and liquid levels during pump cycles. Block(s) should be placed below an access opening and level upon the tank bottom. For two blocks, orient them perpendicular to ribs on the tank bottom, if present, for stability.

Installation of products such as electrical conduit and wiring, pumps, water level control equipment, valves, siphon equipment, etc. shall be in accordance with the product manufacturer's instructions and compliant with applicable state or local rules and regulations. Appurtenances shall be fastened to the tank riser system and not the tank body or access opening rim. Where possible, appurtenances shall be installed to facilitate maintenance and repair access via the tank access openings.

**Note: Prefabricated pump vaults may be installed.**

## GENERAL SPECIFICATIONS

- Failure to comply with installation instructions will void warranty.
- Prior to ground disturbance, check for subsurface obstructions and utilities in conformance with applicable requirements.
- Operating water temperature shall be less than 100° F (40° C).
- In cold conditions, handle and backfill tank with care to prevent impact damage.
- Tanks are not fire resistant. Store away from ignition sources.
- Removal of structural bulkheads is prohibited; removal of locking clips on the tank mid-seam connection is also prohibited.
- Only suitable for potable applications if the tank bears the NSF/ANSI 61 certification mark. Otherwise, tank is recommended for use in septic, rainwater/stormwater storage, holding, and pump applications, or other non-potable uses.
- In applications when allowed by state and local regulations, when using lower inlet and outlet ports, a bulkhead fitting is required. Space constraints at inlet and outlet ports can limit the size of the bulkhead fitting. Typically, 2 or 3" bulkhead fittings is the maximum allowable size that will fit. The designer or contractor should verify a specific bulkhead fit on the Infiltrator tank prior to installation.
- Infiltrator tanks shall not be installed above ground. Contact Infiltrator if the 6-inch (150-mm) minimum soil cover depth cannot be met.



**Table 2: Nominal Volume Chart in U.S. Gallons**

Liquid height above tank bottom <sup>1</sup>		U.S. gallons at indicated height (measured from tank bottom to liquid surface) <sup>1</sup>					
		IM-300	IM-540	IM-1060	CM-1060	IM-1250	IM-1530
in	cm						
1	3	2	3	3	5	6	17
2	5	6	8	13	17	19	34
3	8	10	14	28	31	35	51
4	10	15	21	46	50	55	68
5	13	20	29	65	70	78	94
6	15	26	37	86	91	102	122
7	18	31	46	107	113	127	152
8	20	37	55	129	137	153	180
9	23	43	64	152	160	180	212
10	25	49	74	176	185	208	245
11	28	55	84	200	210	236	280
12	30	62	94	225	236	265	312
13	33	68	105	251	262	294	351
14	36	75	116	277	288	324	387
15	38	82	127	303	315	354	422
16	41	89	138	330	342	385	464
17	43	96	150	357	369	415	500
18	46	103	161	384	396	446	537
19	48	111	173	411	423	477	575
20	51	118	186	438	451	508	614
21	53	126	198	465	478	539	652
22	56	133	210	493	506	571	690
23	58	141	223	521	534	602	729
24	61	148	235	549	562	634	770
25	64	156	248	577	591	666	808
26	66	164	261	605	619	698	847
27	69	172	274	633	648	740	887
28	71	180	287	662	677	781	928
29	74	187	300	691	706	813	968
30	76	195	313	719	734	845	1,007
31	79	202	326	747	762	877	1,048
32	81	210	338	775	790	908	1,087
33	84	217	351	802	818	940	1,126
34	86	224	363	830	846	971	1,165
35	89	231	375	857	873	1,002	1,204
36	91	238	387	884	901	1,033	1,242
37	94	245	399	911	928	1,064	1,280
38	97	251	411	938	955	1,094	1,318
39	99	258	422	965	982	1,125	1,355
40	102	264	433	992	1,008	1,155	1,393
41	104	270	444	1,018	1,035	1,185	1,430
42	107	276	455	1,044	1,061	1,214	1,466
43	109	282	465	1,069	1,087	1,243	1,502
44	112	287	475	1,094	1,111	1,271	1,537
45	114	293	485	1,118	1,136	1,299	1,572
46	117	298	494	1,142	1,160	1,326	1,604
47	119	303	503	1,165	1,184	1,352	1,638
48	122	308	512	1,187	1,206	1,377	1,667
49	124	312	520	1,208	1,228	1,401	1,697
50	127	314	528	1,228	1,248	1,424	1,724
51	130	-	535	1,247	1,267	1,444	1,749
52	132	-	542	1,265	1,282	1,460	1,766
53	135	-	547	1,278	1,293	1,473	1,777
54	137	-	551 <sup>2</sup>	1,287	1,300 <sup>2</sup>	1,478 <sup>2</sup>	1,785 <sup>2</sup>

**Notes:**

- Liquid height measured from lowermost inside surface at bottom of corrugation in tank to the liquid surface elevation.
- The total capacity of the IM-540 tank is 552 gallons; the total capacity of the CM-1060 is 1,309 gallons; the total capacity of the IM-1250 is 1,479 gallons; the total capacity of the IM-1530 tank is 1,787 gallons.
- To determine the liquid volume between two heights, subtract the Table 2 volume indicated for the upper and lower heights. Example: CM-1060 volume between 50 in (127 cm) and 40 in (102 cm) = 1,248 gal – 1,008 gal = 240 gal.

**Table 3: Nominal Volume Chart in Liters**

Liquid height above tank bottom <sup>1</sup>		Liters at indicated height (measured from tank bottom to liquid surface) <sup>1</sup>					
in	cm	IM-300	IM-540	IM-1060	CM-1060	IM-1250	IM-1530
1	3	7	11	11	21	23	64
2	5	22	30	49	64	71	128
3	8	39	53	106	119	133	192
4	10	58	80	174	188	209	256
5	13	77	109	246	263	294	357
6	15	98	141	326	344	385	463
7	18	118	173	405	429	480	573
8	20	140	207	488	517	579	681
9	23	162	243	575	608	681	802
10	25	185	279	666	700	786	928
11	28	209	317	757	795	893	1,061
12	30	234	356	852	892	1,003	1,182
13	33	259	396	950	991	1,114	1,328
14	36	284	437	1,049	1,091	1,227	1,463
15	38	310	480	1,147	1,192	1,341	1,597
16	41	337	523	1,249	1,293	1,456	1,756
17	43	364	566	1,351	1,396	1,572	1,892
18	46	391	611	1,454	1,499	1,688	2,034
19	48	419	656	1,556	1,602	1,805	2,177
20	51	447	702	1,658	1,706	1,923	2,322
21	53	475	749	1,760	1,811	2,041	2,468
22	56	504	796	1,866	1,916	2,160	2,612
23	58	533	843	1,972	2,022	2,280	2,758
24	61	562	891	2,078	2,129	2,400	2,914
25	64	592	940	2,184	2,236	2,521	3,058
26	66	622	988	2,290	2,344	2,643	3,208
27	69	652	1,038	2,396	2,453	2,799	3,356
28	71	681	1,088	2,506	2,563	2,955	3,513
29	74	709	1,137	2,616	2,671	3,077	3,665
30	76	738	1,185	2,722	2,778	3,198	3,814
31	79	766	1,233	2,828	2,885	3,318	3,966
32	81	794	1,281	2,934	2,991	3,438	4,113
33	84	821	1,328	3,036	3,096	3,557	4,262
34	86	848	1,375	3,142	3,201	3,675	4,410
35	89	874	1,421	3,244	3,305	3,793	4,557
36	91	901	1,466	3,346	3,409	3,910	4,701
37	94	926	1,511	3,449	3,512	4,026	4,846
38	97	951	1,555	3,551	3,614	4,142	4,988
39	99	976	1,598	3,653	3,716	4,257	5,131
40	102	1,000	1,640	3,755	3,817	4,371	5,272
41	104	1,023	1,681	3,854	3,917	4,484	5,412
42	107	1,045	1,722	3,952	4,016	4,595	5,550
43	109	1,067	1,761	4,047	4,113	4,705	5,685
44	112	1,088	1,799	4,141	4,207	4,812	5,817
45	114	1,108	1,836	4,232	4,302	4,917	5,950
46	117	1,128	1,871	4,323	4,393	5,019	6,070
47	119	1,147	1,905	4,410	4,481	5,118	6,201
48	122	1,164	1,938	4,493	4,566	5,213	6,310
49	124	1,180	1,970	4,573	4,648	5,304	6,422
50	127	1,188	1,999	4,648	4,724	5,389	6,527
51	130	-	2,027	4,720	4,794	5,465	6,621
52	132	-	2,050	4,789	4,851	5,527	6,684
53	135	-	2,071	4,838	4,896	5,575	6,726
54	137	-	2,08 <sup>2</sup>	4,872	4,922 <sup>2</sup>	5,595 <sup>2</sup>	6,758 <sup>2</sup>

**Notes:**

1. Liquid height measured from lowermost inside surface at bottom of corrugation in tank to the liquid surface elevation.
2. The total capacity of the IM-540 tank is 2,090 liters; the total capacity of the CM-1060 is 4,955 liters; the total capacity of the IM-1250 is 5,599 liters; the total capacity of the IM-1530 tank is 6,765 liters.
3. To determine the liquid volume between two heights, subtract the Table 3 volume indicated for the upper and lower heights. Example: CM-1060 volume between 50 in (127 cm) and 40 in (102 cm) = 4,724 liters – 3,817 liters = 907 liters.

## INLET AND OUTLET HOLE LOCATIONS

Drill height marks are provided on all Infiltrator tank models to guide inlet and outlet hole drilling. A single drill height mark is provided at each end or side port on tanks (example illustrated below). Holes may be drilled at the end or side inlet and outlet locations, as allowed by state and/or local regulations. The drill height mark indicates the center point location

for the hole saw. The pilot drill bit on the hole saw should be positioned at the center of the drill height mark to align the hole saw properly. Table 4 provides drilling and invert information by regulatory jurisdiction for the installation of 4-inch-diameter (100 mm) pipe. Use the Infiltrator Invert Drop Drill Position Tool to adjust for the Florida invert drop height.

**Table 4: Inlet and Outlet Hole Locations<sup>1</sup>**

Jurisdiction <sup>2</sup>	Inlet Drill Location	Outlet Drill Location	Invert Drop (in) [mm]	Inlet Invert Height (in) [mm]		Outlet Invert Height <sup>3</sup> and Liquid Level (in) [mm]
				Above Inside Bottom of Tank <sup>3</sup>	Above Excavation Base <sup>4</sup>	
<b>IM-300</b>						
All	All	All	2.00 [51]	43.25 [1,099]	43.45 [1,104]	41.25 [1,048]
<b>IM-540, CM-1060, IM-1250, IM-1530</b>						
All Except Florida	All	All	3.00 [76]	47.00 [1,194]	47.20 [1,199]	44.00 [1,118]
Florida	End	End	2.00 [51]	46.00 [1,168]	46.20 [1,174]	44.00 [1,118]
<b>IM-1060</b>						
All Except Florida	End	End	3.00 [76]	47.00 [1,194]	47.20 [1,199]	44.00 [1,118]
	Side	Side	3.00 [76]	47.50 [1,207]	47.70 [1,212]	44.50 [1,130]
	Side	End	3.50 [89]	47.50 [1,207]	47.70 [1,212]	44.00 [1,118]
	End	Side	2.50 [64]	47.00 [1,194]	47.20 [1,199]	44.50 [1,130]
Florida	End	End	2.00 [51]	46.00 [1,168]	46.20 [1,174]	44.00 [1,118]

1. State, provincial, and local regulatory requirements supersede Table 4 information.

2. Kentucky and West Virginia tanks are factory-drilled. Florida and Oregon tanks must be factory- or distributor-drilled.

3. Invert heights are measured from the lowest interior surface at the bottom of the tank to the invert.

4. Invert heights are measured from the base of the excavation to the invert.

### Installation Terminology

- “Subsurface water” refers to a water-saturated zone of soil. Do not install if subsurface water is continuous from the tank bottom elevation to any point above the outlet pipe saddle elevation.
- “Uninterrupted saturated soil” refers to water-saturated soil with no gaps in the saturated condition. An example of a gap in the saturated condition is a perched water table, when two water-saturated soil zones are interrupted by an unsaturated soil zone. Do not install if uninterrupted saturated soil is present from the tank bottom elevation to any point above the outlet pipe saddle elevation.
- A perched water table is allowable above the outlet pipe saddle elevation only if unsaturated soil is present between the perched water table and tank bottom elevation.

### Limitations When Subsurface Water is Present Above the Tank Bottom

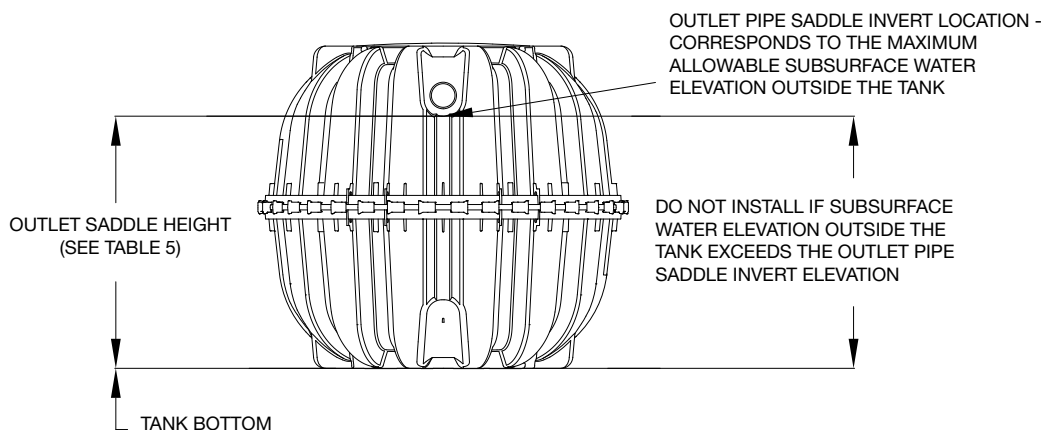

Tank Model	Outlet Saddle Height
IM-300	40.75 in (1,035 mm)
IM-540	43.00 in (1,092 mm)
IM-1060	43.00 in (1,092 mm)
CM-1060	43.00 in (1,092 mm)
IM-1250	43.00 in (1,092 mm)
IM-1530	43.00 in (1,092 mm)



**Infiltrator Water Technologies, LLC ("Infiltrator")**

**INFILTRATOR® SEPTIC TANK LIMITED WARRANTY FIVE (5) YEAR MATERIALS AND WORKMANSHIP LIMITED WARRANTY**

- (a) This limited warranty is extended to the end user of an Infiltrator Tank. A Tank manufactured by Infiltrator, when installed and operated in accordance with Infiltrator's installation instructions and local regulation by a person or company that is properly qualified to install the Infiltrator Tank in accordance with applicable state and/or local requirements, is warranted to you: (i) against defective materials and workmanship for five (5) years after installation. Infiltrator will, at its option, (i) repair the defective product or (ii) replace the defective materials. Infiltrator's liability specifically excludes the cost of removal and/or installation of the Tank.
- (b) In order to exercise its warranty rights, you must notify Infiltrator in writing at its corporate headquarters in Old Saybrook, Connecticut within fifteen (15) days of the alleged defect.
- (c) YOUR EXCLUSIVE REMEDY WITH RESPECT TO ANY AND ALL LOSSES OR DAMAGES RESULTING FROM ANY CAUSE WHATSOEVER SHALL BE SPECIFIED IN SUBPARAGRAPH (a) ABOVE. INFILTRATOR SHALL IN NO EVENT BE LIABLE FOR ANY CONSEQUENTIAL OR INCIDENTAL DAMAGES OF ANY KIND, HOWEVER OCCASIONED, WHETHER BY NEGLIGENCE OR OTHERWISE. SOME STATES DO NOT ALLOW THE EXCLUSION OR LIMITATION OF INCIDENTAL OR CONSEQUENTIAL DAMAGES, SO THIS LIMITATION OR EXCLUSION MAY NOT APPLY TO YOU. THIS WARRANTY GIVES YOU SPECIFIC LEGAL RIGHTS AND YOU MAY ALSO HAVE OTHER RIGHTS WHICH VARY FROM STATE TO STATE.
- (d) THIS LIMITED WARRANTY IS THE EXCLUSIVE WARRANTY GIVEN BY INFILTRATOR AND SUPERSEDES ANY PRIOR, CONTRARY, ADDITIONAL, OR SUBSEQUENT REPRESENTATIONS, WHETHER ORAL OR WRITTEN. INFILTRATOR DISCLAIMS AND EXCLUDES TO THE GREATEST EXTENT ALLOWED BY LAW ALL OTHER WARRANTIES, WHETHER EXPRESS OR IMPLIED, OR STATUTORY, INCLUDING ANY WARRANTY OF MERCHANTABILITY, FINESSE FOR A PARTICULAR PURPOSE AND ANY IMPLIED WARRANTIES OTHERWISE ARISING FROM COURSE OF DEALING, COURSE OF PERFORMANCE, OR USAGE OF TRADE. NO PERSON (INCLUDING ANY EMPLOYEE, AGENT, DEALER, OR REPRESENTATIVE) IS AUTHORIZED TO MAKE ANY REPRESENTATION OR WARRANTY CONCERNING THIS PRODUCT, EXCEPT TO REFER YOU TO THIS LIMITED WARRANTY. EXCEPT AS EXPRESSLY SET FORTH HEREIN, THIS WARRANTY IS NOT A WARRANTY OF FUTURE PERFORMANCE, BUT ONLY A WARRANTY TO REPAIR OR REPLACE.
- (e) YOU MAY ASSIGN THIS LIMITED WARRANTY TO A SUBSEQUENT PURCHASER OF YOUR HOME.
- (f) NO REPRESENTATIVE OF INFILTRATOR HAS THE AUTHORITY TO CHANGE THIS LIMITED WARRANTY IN ANY MANNER WHATSOEVER, OR TO EXTEND THIS LIMITED WARRANTY.
- (g) NO WARRANTY OF ANY KIND IS MADE WITH REGARD TO ANY PRODUCT, COMPONENTS, DEVICES, MEDIA OR TREATMENT UNITS WHICH ARE MANUFACTURED BY OTHERS AND ARE INSTALLED IN AN INFILTRATOR TANK. USE OF THESE PRODUCTS ARE AT YOUR OWN RISK.
- (h) THE INFILTRATOR TANK IS DESIGNED TO BE BURIED UNDERGROUND. NO WARRANTY OF ANY KIND IS MADE IF YOUR TANK IS NOT BURIED UNDERGROUND AS SPECIFIED IN THE PRODUCT'S INSTALLATION INSTRUCTIONS.

**CONDITIONS AND EXCLUSIONS**

There are certain conditions or applications over which Infiltrator has no control. Defects or problems as a result of such conditions or applications are not the responsibility of Infiltrator and are NOT covered under this warranty. They include failure to install the Tank in accordance with instructions or applicable regulatory requirements or guidance, altering the Tank contrary to the installation instructions and disposing of chemicals or other materials contrary to normal tank usage.

The above represents the Standard Limited Warranty offered by Infiltrator. A limited number of regulatory jurisdictions have different warranty requirements. Any purchaser of a Tank should contact Infiltrator's corporate headquarters in Old Saybrook, Connecticut, prior to such purchase to obtain a copy of the applicable warranty, and should carefully read that warranty prior to the purchase of a Tank.



**INFILTRATOR**  
water technologies

4 Business Park Road  
P.O. Box 768  
Old Saybrook, CT 06475  
860-577-7000 • Fax 860-577-7001  
**1-800-221-4436**  
[www.infiltratorwater.com](http://www.infiltratorwater.com)  
[info@infiltratorwater.com](mailto:info@infiltratorwater.com)

**Distributed By:**

**Note: Please visit [www.infiltratorwater.com](http://www.infiltratorwater.com) for updated and/or amended instructional material.**

For U.S. Patents information visit [www.infiltratorwater.com/patents](http://www.infiltratorwater.com/patents). Other patents pending. Infiltrator, Quick4 and EZflow are registered trademarks of Infiltrator Water Technologies. Infiltrator Water Technologies is a wholly-owned subsidiary of Advanced Drainage Systems, Inc. (ADS).

Attachment 3

Riser Connection Guidance

# Infiltrator Tank Riser Connection

## Guidance Document for EZsnap Risers



### Before You Begin

This document provides recommended procedures for the connection of EZsnap Riser products to Infiltrator Water Technologies (Infiltrator's) tanks.

The intent of this document is to provide procedures for making the connection between the riser and tank. Risers must be installed according to state and/or local regulations, which supersede the guidelines in this document. If unsure of the requirements for a particular site, contact the local health department or permitting authority.

**Note:** The method of PVC and HDPE riser construction shown in this document is not allowed under Florida regulations.

### Parts and Supplies

The parts and supplies necessary for installation of a riser system on Infiltrator tanks must be purchased separately from the tank. All parts and supplies are commercially available. Contact Infiltrator or the riser manufacturer for assistance obtaining any of the following parts and supplies.

Infiltrator Riser Products	
Item	Item Number
EZsnap Tank Pipe Adapter Ring	SNAPPAR-2400
EZsnap 24" x 2" Riser (Green)	SNAPIS-2402
EZsnap 24" x 6" Riser (Green)	SNAPIS-2406
EZSnap 24" x 12" Riser (Green)	SNAPIS-2412
EZsnap 24" Safety Lid System	SNAPSFT-2400
24" Riser Lid (Green)	IMLID-2400
Adhesive Sealant	ISI-1500 (or E6100 as equivalent)
Infiltrator Safety Star	SNAPSFT-2400



Risers nest together for efficient shipping.

### Materials and Equipment Needed for EZsnap Riser Installation

- Rubber mallet
- Screw gun
- Ten #14 x 2" stainless steel tank-to-riser screws (supplied with EZsnap Riser)
- Ten #14 x 2" stainless steel lid screws with washers (supplied with Infiltrator tanks)

- 7/16" hex nut driver screw gun bit
- #3 square head Robertson driver bit, 6" (150 mm) length
- #2 Phillips driver bit, 6" (150 mm) length
- 3/8" hex nut driver screw gun bit
- Rags

**Note:** Install riser assembly prior to backfilling tank.

**Note:** The EZsnap Riser segment includes factory-installed gaskets on both ends of the riser segment, so the application of a sealant or mastic on the connection

surface is not required. Proper care must be taken to ensure the gasket surface is clean and free of debris. It is recommended that all gaskets and connection surfaces be wiped clean.



Engage one set of tabs into proper position.

Each riser section is tapered to have a narrow end and a wide end. When shipped, the EZsnap Risers are stacked wide end down and nested together. When making riser connections, the narrow ends are designed to connect to the narrow end and the wide end is designed to connect to the wide end. It is a recommended best practice that the taller sections be installed at the deepest points of the installation.



Use mallet to engage the rest of the tabs.

### Riser-to-Tank Connection

Insert the EZsnap Riser narrow end down into the tank opening. Rotate the riser until the riser connection tabs align with the tank indexing tabs on the tank opening. Screw pilot holes will be in alignment on the riser and tank when in proper position. On one side of the tank, insert the riser connection tabs into the tank indexing tabs and engage into the proper position. Using a rubber mallet pound downward on the top of the riser to engage the remaining tabs. It is helpful to move around the circumference of the tank opening while engaging tabs. **A screwed connection is only required for the tank-to-riser interface, created using the ten #14 x 2" stainless steel tank-to-riser screws supplied with the EZsnap Riser.** Tighten screws in a star pattern, alternately tightening screws on opposite sides of the EZsnap Riser.

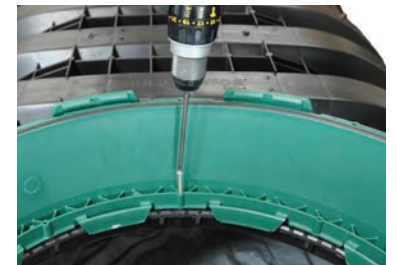

Screws required for riser to tank connection only.



Risers are available in 2", 6" and 12" height for desired finished height.



## Riser-to-Riser Connection

The EZsnap Risers come in multiple heights to align with the desired finished grade. Each riser is tapered to have a large end and small end align with like-diameter ends of riser segments. Rotate until the tabs on the upper riser segment drop into alignment on the lower riser segment. With tabs in alignment, push directly down on the top rim of the upper riser segment until the connection tab engages into the lower riser segment. A rubber mallet may be necessary to engage the tabs by striking the top surface of the riser if manual pressure is not adequate.

## Infiltrator Safety Star Installation

The Infiltrator Safety Star is designed to be mounted to the screw pilot holes at a narrow-end riser connection. One arm on the Safety Star folds down 15 degrees, allowing it to collapse and fit through a 24" (600 mm) opening.



1. Install the Safety Star at the EZsnap narrow riser-to-riser connection closest to the ground surface. A minimum of a 6" (150 mm) riser is required to accommodate the Safety Star and attach the lid properly.
2. Fasten the Safety Star in place using #14 x 2" stainless steel screws (supplied with the EZsnap Risers).



*Infiltrator's five arm Safety Star system is equipped with a folding arm for easy installation.*

## Lid-to-Riser Connection

The EZsnap Lid will accommodate both the narrow and the wide end of the riser. To install, set the lid on top of the uppermost riser segment and rotate until the riser tabs recess into the receiving pockets on the lid. The lid will drop downward approximately 1/2" (13 mm) and stop rotating when seated properly. With the lid properly seated, the screw pilot holes are in alignment.



*Set lid on uppermost riser segment and rotate to receiving pocket on riser.*

Use the ten #14 x 2" stainless steel lid screws with washers provided with the tank to fasten the lid to the riser. There are nine hexagonal head stainless steel bolts and one #3 pan-head Robertson screw, which is used as a tamper-resistant fastener. Depending upon which end of a riser segment is being used for the lid connection, use the outer-diameter screw pilot holes on the lid for the larger-diameter end of the riser and the inner-diameter screw holes for the smaller-diameter end of the riser. Call-outs on the lids clearly define the proper screw pilot holes to use for the different bolt patterns. Adjust the screw gun settings to prevent stripping-out the pilot holes. Do not over-tighten screws.



*Prior to backfilling, fasten the lid to the riser with screws provided.*

## Materials and Equipment Needed for Riser Pipe Installation

- Screw gun
- Caulk gun and ISI-1500 sealant or equivalent
- Marker or marking pencil
- Brush
- Rags
- Infiltrator Pipe Adapter Ring (SNAPPAR-2400)
- Adhesive-backed gasket (supplied with SNAPPAR-2400)
- Ten #14 x 2" stainless steel lid screws with washers (supplied with lid)
- Ten #14 x 2" stainless steel SNAPPAR-2400-to-tank screws (supplied with SNAPPAR-2400)
- Four #12 x 1/2" (for IPEX, Ultra-Rib™ PVC pipe) or #12 x 1/4" (for HDPE pipe) stainless steel screws (not provided)
- 7/16" hex nut driver screw gun bit
- #3 square head Robertson driver bit, 6" (150 mm) length
- #2 Phillips driver bit, 6" (150 mm) length
- 3/8" hex nut driver screw gun bit

## 24" (600-mm) IPEX, Ultra-Rib™ PVC Pipe

**Note:** Method not allowed in Florida

**Note:** 24" (600-mm) IPEX pipe must be installed using the Infiltrator Pipe Adapter Ring.

1. Install riser assembly prior to backfilling tank.
2. Cut IPEX pipe along an inner corrugation to allow lid to fit properly, taking care that the cut is smooth and even.

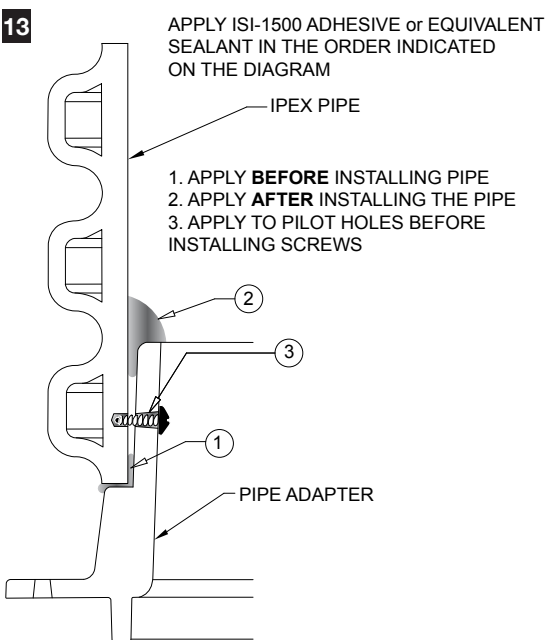

3. Apply two continuous 3/8" (10 mm) beads of adhesive sealant to the smaller of the two standing ribs closest to the screw pilot holes on the top surface of the tank opening. Add an extra dab of sealant in each screw hole. Sealant thickness must fill gap beneath Infiltrator Pipe Adapter Ring.

4. Align the Infiltrator Pipe Adapter Ring with the tank opening by lining up the arrows on the Infiltrator Pipe Adapter Ring with the arrow on the tank inlet or outlet. The ring will seat on the tank tightly when properly aligned. Center and press to create an even distribution of the sealant.

5. Fasten Infiltrator Pipe Adapter Ring to the tank opening using ten #14 x 2" stainless steel SNAPPAR-2400-to-tank screws. Tighten in a star pattern. Repeat the star pattern at least twice, without over-tightening screws.

6. Mark four evenly distributed locations on the inside of the Infiltrator Pipe Adapter Ring for pilot holes to accept screws. The pilot holes should be at a height half way up the interior flange of the Infiltrator Pipe Adapter Ring.

7. Drill four 1/8" (3.5-mm) pilot holes at marked locations on the Infiltrator Pipe Adapter Ring.

8. Apply one bead of adhesive sealant to the first taper on the Infiltrator Pipe Adapter Ring.

9. Place the IPEX pipe over the Infiltrator Pipe Adapter Ring until it is seated at the base of the flange.

10. Insert adhesive sealant into the four pre-drilled pilot holes.

11. Fasten IPEX pipe to Infiltrator Pipe Adapter Ring using four #12 x 1/2" stainless steel screws from the inside of pipe.

12. Tighten screws in a star pattern, tightening screws alternately on opposite sides of the Infiltrator Pipe Adapter Ring. Repeat the star pattern at least twice, without over-tightening screws.

13. Apply a generous bead of sealant into the groove at the top of the pipe adapter and then smear the sealant into the groove between the pipe and Infiltrator Pipe Adapter Ring.

14. Use the Infiltrator lid or equivalent product as a lid for the riser pipe. The lid will require the installation of the factory-supplied, adhesive-backed gasket to the bottom side of the lid to ensure a snug fit. Set and center the lid onto the riser pipe. Pre-drill 1/8" (3.5-mm) pilot holes on the inner set of templated locations on the lid. Fasten using the ten factory-supplied #14 x 2" stainless steel lid screws with washers.

**Note:** When using the Infiltrator lid, apply the factory-supplied, adhesive-backed gasket to the bottom side of the lid to ensure a snug fit.

15. Backfill tank in accordance with Infiltrator's tank installation instructions.

16. Following tank backfilling, visually examine the riser-to-Infiltrator Pipe Adapter Ring connection for damage resulting from backfill placement. Repair or replace if damaged. Allow 24-hour sealant cure time before testing or putting into service.





## 24" (600-mm) HDPE Pipe

**Note:** Method not allowed in Florida

**Note:** The 24" (600-mm) HDPE pipe must be installed using the Infiltrator Pipe Adapter Ring.

1. Install riser assembly prior to backfilling tank.
2. Cut IPEX pipe along an inner corrugation to allow lid to fit properly, taking care that the cut is smooth and even.
3. Apply two continuous 3/8" (10 mm) beads of adhesive sealant to the smaller of the two standing ribs closest to the screw pilot holes on the top surface of the tank opening. Add an extra dab of sealant in each screw hole. Sealant thickness must fill gap beneath Infiltrator Pipe Adapter Ring.
4. Align the Infiltrator Pipe Adapter Ring with the tank opening by lining up the arrows on the Infiltrator Pipe Adapter Ring with the arrow on the tank inlet or outlet. The ring will seat on the tank tightly when properly aligned. Center and press to create an even distribution of the sealant.
5. Fasten Infiltrator Pipe Adapter Ring to the tank opening using ten #14 x 2" stainless steel SNAPPAR-2400-to-tank screws. Tighten in a star pattern. Repeat the star pattern at least twice, without over-tightening screws.
6. Mark four evenly distributed locations on inside of the the Infiltrator Pipe Adapter Ring for pilot holes to accept screws. The pilot holes should be at a height half way up the interior flange of the Infiltrator Pipe Adapter Ring.
7. Drill four 1/8" (3.5-mm) pilot holes at marked locations on the Infiltrator Pipe Adapter Ring.
8. Center the HDPE pipe over the Infiltrator Pipe Adapter Ring.
9. Fasten the HDPE pipe to the Infiltrator Pipe Adapter Ring using four #12 x 1 1/4" stainless steel screws from inside the pipe.

10. Tighten screws in a star pattern, tightening screws on opposite sides of the Infiltrator Pipe Adapter Ring. Repeat the star pattern at least twice, without over-tightening screws.

11. Apply adhesive sealant in the space between the pipe and Infiltrator Pipe Adapter Ring to seal the gap between the pipe and adapter ring.

12. Use the Infiltrator lid or equivalent product as a lid for the riser pipe. The lid will require the installation of the factory-supplied, adhesive-backed gasket to the bottom side of the lid to ensure a snug fit. Set and center the lid onto the riser pipe. Pre-drill 1/8" (3.5-mm) pilot holes on the inner set of templated locations on the lid. Fasten using the ten factory-supplied #14 x 2" stainless steel lid screws with washers.

**Note:** When using the Infiltrator lid, apply the factory-supplied, adhesive-backed gasket to the bottom side of the lid to ensure a snug fit.

13. Backfill tank in accordance with Infiltrator's tank installation instructions.

14. Following tank backfilling, visually examine the riser-to-Infiltrator Pipe Adapter Ring connection for damage resulting from backfill placement. Repair or replace if damaged. Allow 24-hour sealant cure time before testing or putting into service.

## Backfilling Tank and Risers

Backfill tank and risers in lifts in accordance with Infiltrator Tank General Installation Instructions, supporting all sides of the risers as the backfill height increases.

**Note:** Always install and secure lids prior to backfill placement.

*Disclaimer: These recommended procedures have been developed to identify best practices for achieving a watertight connection between the tank and riser under typical tank installation conditions. These procedures have been shown to result in a watertight connection between the riser assemblies identified in this document and the Infiltrator tank. Infiltrator does not guarantee a watertight connection between tank and riser because achieving a watertight connection is dependent upon a combination of installer practices and procedures, and field conditions. Please contact Infiltrator's Technical Services Department at 800-221-4436 if difficulty is encountered during riser installation. Please contact the appropriate riser manufacturer for concerns associated with anything that does not involve the tank-to-riser connection.*



**INFILTRATOR**  
water technologies

4 Business Park Road  
P.O. Box 768  
Old Saybrook, CT 06475  
860-577-7000 • Fax 860-577-7001  
**(800) 221-4436**  
[www.infiltratorwater.com](http://www.infiltratorwater.com)  
[info@infiltratorwater.com](mailto:info@infiltratorwater.com)

For U.S. Patents information visit [www.infiltratorwater.com/patents](http://www.infiltratorwater.com/patents). Other patents pending. Infiltrator, Quick4 and EZflow are registered trademarks of Infiltrator Water Technologies. Infiltrator Water Technologies is a wholly-owned subsidiary of Advanced Drainage Systems, Inc. (ADS).

© 2023 Infiltrator Water Technologies, LLC. Not responsible for any typographic errors. Printed in U.S.A.

TANK02 0723

**Contact Infiltrator Water Technologies' Technical Services Department for assistance at 1-800-221-4436**

Attachment 4

CSA Certification  
(to be provided under separate cover)



Attachment 5  
Draft Approval Letter

DATE

Ms. Mariya Moskovets  
Infiltrator Water Technologies  
4 Business Park Road  
P. O. Box 768  
Old Saybrook, CT 06475

Subject: Product Registration, Infiltrator IM-300 tank

Dear Ms. Moskovets:

The Division of Environmental Health has completed a review of a registration application for the subject products. This information was submitted pursuant to Section 7 of the Subsurface Wastewater Disposal Rules for registration for use in Maine.

The IM-300 consists of two-piece high-density polyethylene/polypropylene tank halves. The seam between the upper and lower halves is sealed with an elastomeric gasket. The IM-300 septic tank must be installed in series per Section 7(G)(5) of the Rules to obtain the minimum required liquid capacity. Risers are available for the IM-300 tank.

Pursuant to Section 7 of the Rules, a product must be based upon sound engineering principles and can be expected to provide the same level of protection to public health and the environment as offered by the authorized products presently authorized by the Department for use in these Rules. According to the information you provided, the IM-300 received a IAPMO R&T listing current as of December 2023.

Based on the information submitted, the Division has determined that Infiltrator's IM-300 tank is acceptable for use in the State of Maine, provided that it is installed, operated, and maintained in conformance with the manufacturer's directions. Because installation and owner maintenance have a significant effect on the working order of onsite sewage disposal systems, including their components, the Division makes no representation or guarantee as to the efficiency and/or operation of the IM-300 tank. Further, registration of this product for use in the State of Maine does not represent Division preference or recommendation for this product over similar or competing products.

If you have any questions, please feel free to contact me at (207) 287-5695.

Sincerely,

Alexander L. Pugh  
Sr. Environmental Hydrogeologist  
Division of Environmental Health  
Subsurface Wastewater Team  
e-mail: [alex.l.pugh@maine.gov](mailto:alex.l.pugh@maine.gov)

DATE

Ms. Mariya Moskovets  
Infiltrator Water Technologies  
4 Business Park Road  
P. O. Box 768  
Old Saybrook, CT 06475

Subject: Product Registration, Infiltrator IM-1250 tank

Dear Ms. Moskovets:

The Division of Environmental Health has completed a review of a registration application for the subject products. This information was submitted pursuant to Section 7 of the Subsurface Wastewater Disposal Rules for registration for use in Maine.

The IM-1250 consists of two-piece high-density polyethylene/polypropylene tank halves. The seam between the upper and lower halves is sealed with an elastomeric gasket. The IM-1250 tank has a 1,271-gallon capacity when used as a single- or dual-compartment septic tank. Risers are available for the IM-1250 tank.

Pursuant to Section 7 of the Rules, a product must be based upon sound engineering principles and can be expected to provide the same level of protection to public health and the environment as offered by the authorized products presently authorized by the Department for use in these Rules. According to the information you provided, the IM-1250 received a IAPMO R&T listing current as of January 2024.

Based on the information submitted, the Division has determined that Infiltrator's IM-1250 tank is acceptable for use in the State of Maine, provided that it is installed, operated, and maintained in conformance with the manufacturer's directions. Because installation and owner maintenance have a significant effect on the working order of onsite sewage disposal systems, including their components, the Division makes no representation or guarantee as to the efficiency and/or operation of the IM-1250 tank. Further, registration of this product for use in the State of Maine does not represent Division preference or recommendation for this product over similar or competing products.

If you have any questions, please feel free to contact me at (207) 287-5695.

Sincerely,

Alexander L. Pugh  
Sr. Environmental Hydrogeologist  
Division of Environmental Health  
Subsurface Wastewater Team  
e-mail: alex.l.pugh@maine.gov